

# Inverter Salt Chlorinator

## Operating Instructions



**Mr.Light**

# INDEX

1 Warnings .....	1
2 Product Introduction .....	2
2.1 Product Specification .....	2
2.2 Electronic Connections .....	3
3 Pool Water Preparation.....	4
3.1 Adding Salt .....	5
3.2 Chemical Water Balance .....	5
4 Control Unit Operation .....	6
4.1 General Screen View.....	6
4.2 Chlorine Production Mode Introduction.....	8
4.3 LED Indicator Introduction .....	11
4.4 Basic Commands and Functions .....	12
4.5 External Device .....	22
4.6 Combinations and Operation .....	24
5 Salt Replenishment.....	26
6 Maintenance.....	27
6.1 Cleaning the Electrodes .....	27
6.2 Maintenance of the ORP Probe (Premium).....	27
6.3 Maintenance of the pH Probe .....	28
6.4 Maintenance of the Doser .....	28
7 Winterizing and Low Temp Protection.....	29
8 Overheat Protection .....	29
9 Wi-Fi Instruction.....	29
9.1 Start-Up.....	29
9.2 Device Sharing .....	32
10 Error Code and Solution .....	33
11 After-Sales Support.....	35

# 1 Warnings

## **WARNING: General Information**

1. Carefully read all the instructions in this manual and on the device. Failure to read and comply with the instructions can cause injury. This document must be given to the pool owner / custodian, who should keep it in a safe place for reference.
2. Chemicals can cause internal and external burns. To avoid death, serious injury and/or damage to equipment, always wear personal protective equipment (gloves, goggles, mask, etc.) when servicing or maintaining this device. This device must be installed in an adequately ventilated place.
3. The appliance is not to be used by persons (including children) with reduced physical, sensory, or mental capabilities, or lack of experience and knowledge, unless they have been given supervision or instruction.
4. Children must not play with this device. User maintenance and cleaning must not be carried out by unsupervised children.
5. The chlorinator must be located or fixed so that they cannot fall into the water.
6. Avoid damage due to water freezing.
7. Use only original Aquark parts.

## **WARNING: Electrical Hazard**

1. This equipment is intended to be used on swimming pools only.
2. Disconnect the equipment from the mains supply before any intervention or maintenance.
3. All electrical installations must be carried out by a qualified and approved electrician in accordance with the standards currently in force in the country of installation.
4. Check that the device is plugged into a power outlet that is protected against short-circuits. The device must also be powered via an isolating transformer or a residual current device (RCD) with a nominal operating residual current not exceeding 30 mA.
5. Check that the supply voltage required by the product corresponds to the voltage of the distribution network and that the power supply cables are suitable for the products power demand.
6. To reduce the risk of electric shock, do not use an extension cable to connect the device to the mains. Connect directly to a wall socket.
7. This device must not be used if the power cord is damaged. An electric shock could result. A damaged power cord must be replaced by after-sales service or similarly qualified persons to avoid danger.

## 2 Product Introduction











### 2.1 Product Specification

Model		MLS15	MLS23	MLS31	MLS35
Max. Chlorine Production (g/h) (Salinity: 1000 PPM)		15	23	31	35
pool volume (m <sup>3</sup> ) 1000PPM		40-70	70-95	90-120	100-135
Salt Level (g/L)	1-2g/L (recommended 1g/L)				
Power Supply	AC 220~240V 50/60Hz				
Max. Output Voltage	DC 12V				
Max Power Consumption (W)		135	202	195	220
Advised water flux	5 m <sup>3</sup> /h -28 m <sup>3</sup> /h				
Water Temperature	5°C - 40°C				
Operating Temperature	-5°C - 42°C				
Pressure for Electrolytic Cell	3 Bar				
IP Rating	IP65				
Cell Lifetime	Up to 12000H				

## 2.2 Electronic Connections



### 2.2.1 Control Unit with In-Built pH Regulator



No.	Port Name	Photo	Description	
①	Relay		The internal relay is normally open, used to control the on/off of external water pumps, etc.	
②	In-built pH Doser		Left	Acid inlet
			Right	Acid outlet
③	Power Input		AC power connector (220-240V, 50/60Hz)	
④	Flow Switch		Connector for flow switch	
⑤	Power Output		Terminal for cell power	
⑥	AUX1		External device control, such as inverter water pump	
⑦	AUX2		External device control, such as swimming pool cover signal control.	
⑧	pH		BNC Connector for pH sensor	
⑨	TEMP		BNC Connector for temperature sensor (Integrated with the pH sensor).	
⑩	ORP		BNC Connector for ORP sensor	

## 2.2.2 Control Unit with External pH Regulator

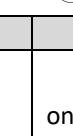
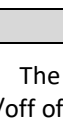

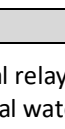
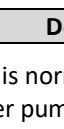
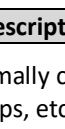
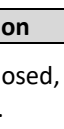
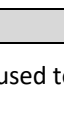
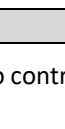
No.	Port Name	Photo	Description
①	Relay		The internal relay is normally closed, used to control the on/off of external water pumps, etc.
②	External pH Doser		External pH Doser decorative panel
③	Power Input		AC power connector (220-240V, 50/60Hz)
④	Flow Switch		Connector for flow switch
⑤	Power Output		Terminal for cell power
⑥	AUX1		External device control, such as inverter water pump
⑦	AUX2		External device control, such as swimming pool cover signal control.
⑧	pH		BNC Connector for pH sensor
⑨	TEMP		BNC Connector for temperature sensor (Integrated with the pH sensor).
⑩	ORP		BNC Connector for ORP sensor

## 3 Pool Water Preparation

To prepare the pool water to enable the chlorinator, its chemical composition must be balanced and salt added. Certain adjustments to the chemical balance of the pool can take several hours.

The procedure **MUST** therefore be started well **BEFORE** the chlorinator is turned on.

### 3.1 Adding Salt

Add the salt 24 hours before turning on the chlorinator with the pump working. Ensure that the recommended amount of salt is not exceeded.

Measure the salt content 6 to 8 hours after the amount has been added to the swimming pool.

**NOTE:**

- If the water in the pool is not fresh and/or if it is liable to contain dissolved metals, use a metal remover, according to the manufacturer's instructions.
- If your water has previously been treated with a product other than chlorine (bromine, hydrogen peroxide, PHMB, etc.), neutralize this product or replace all the water in the pool.
- If using mineral salt (Magnesium chloride and / or Potassium chloride) add approx. 1.4times the amount of normal salt.
- If your water is supplied from a well, shock chlorination with trichloroisocyanuric acid (2 kg/50 m<sup>3</sup> of water).

### 3.2 Chemical Water Balance

The water must be balanced manually **BEFORE** the device is started up.

The following table summarizes the concentrations recommended. Your water should be checked regularly to maintain these concentrations and minimize surface corrosion or deterioration.







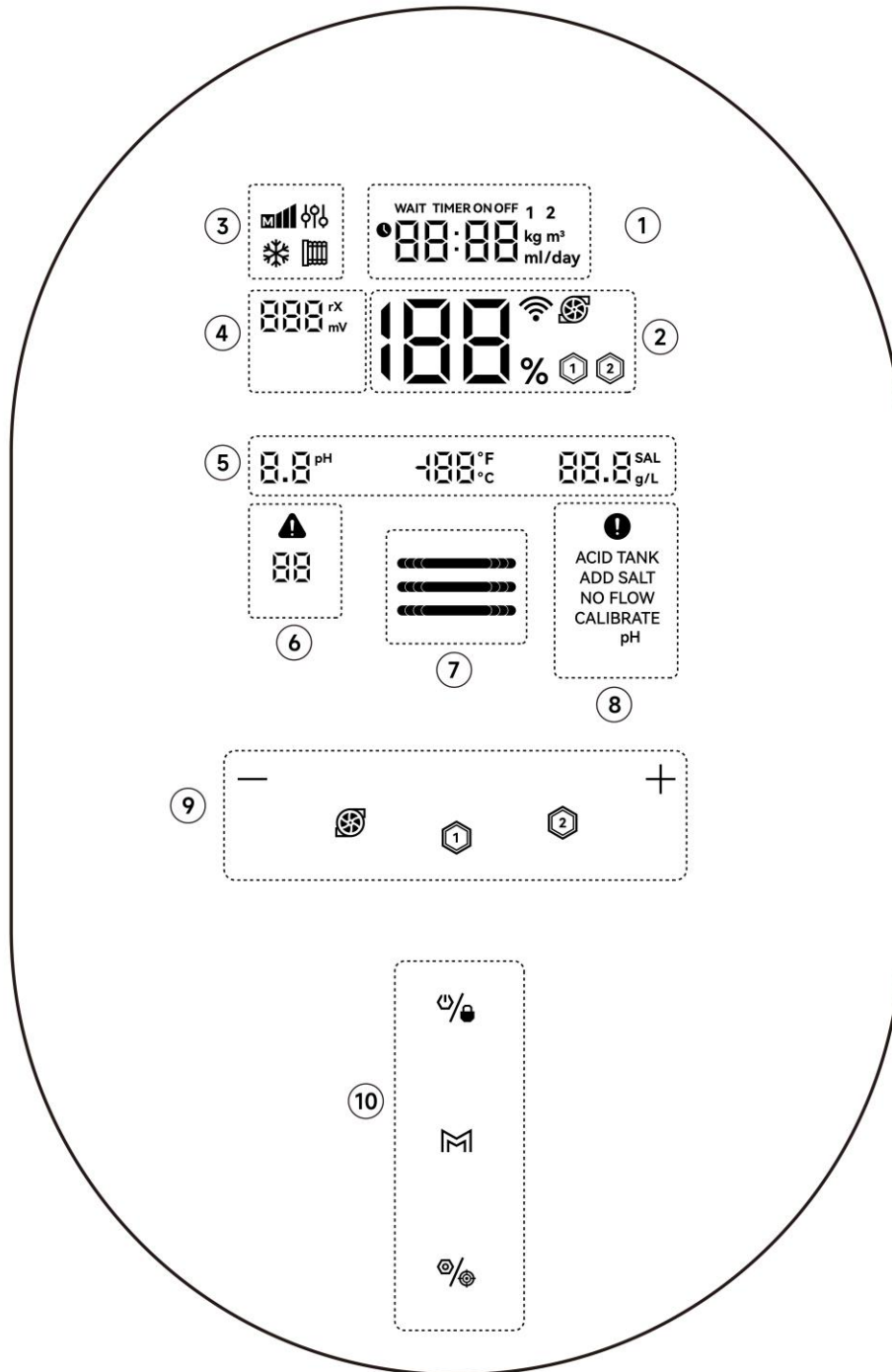



CHEMISTRY	Recommended CONCENTRATIONS
Salt	Salt 1.0-2.0 g/L(Recommended 1 g/L)
Free chlorine	Free chlorine 1.0 to 3.0 ppm
pH	pH 7.2 to 7.6
Cyanuric acid (Stabilizer)	20 to 30 ppm max, 0 ppm in indoor pool (Add stabilizer only if necessary)
Total alkalinity	80 to 120 ppm
Water hardness	200 to 300 ppm
Metals	0 ppm
Algaecide	Use of algaecide is an option, but must be copper free

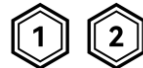





# 4 Control Unit Operation

## 4.1 General Screen View



Marked Area	Description	Icon
①	Main display area : <ul style="list-style-type: none"> <li>● pool volume (m<sup>3</sup>)</li> <li>● turbo mode countdown</li> <li>● time, timer 1 and 2</li> </ul>	

	● acid adding amount (ml/d)	
②	Real-time chlorine production	100%
	The WIFI signal intensity status. Keep Flashing while the WIFI is setting	
	VS pump status	
	External equipment	
③	Manual mode	
	Chlorine production mode in 40% / 100% / 120%	
	Low temperature status	
	Pool cover status	
④	Real-time ORP value (display “---” when the value exceeds 990mV) rX flashes when ORP probe calibration is prompted	000 rX mV
⑤	Real-time pH value (over pH9.9, shows rounded value 10~14, APP shows the specific value)	8.8 pH
	Real-time water temperature value (default display °C, reserved)	100 °F °C
	Real-time salinity value	00.0 SAL g/L
⑥	Error codes	 00
⑦	<b>LED Indicator:</b> ● water quality ● electrolysis ● probe calibration ● distribution network status, ● on / off ● other operating status	
⑧	Warnings	 ACID TANK ADD SALT NO FLOW CALIBRATE pH
⑨	Tuning down	—
	VS Pump control	

	External device 1	
	External device 2	
	Tuning up	
⑩	Power/Lock	
	Chlorine production mode selection	
	Settings/Calibration	



Home Screen

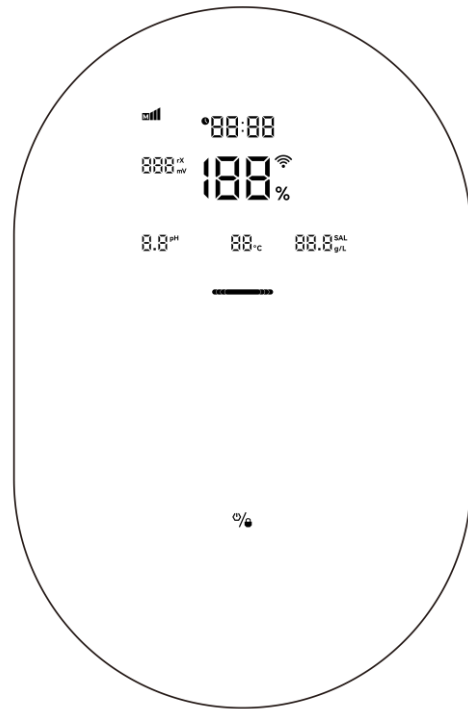

Screen Lock View (Weak brightness)









## 4.2 Chlorine Production Mode Introduction

The chlorinator can be configured to 2 different types according to different chlorine modes.

Configuration		Premium	Medium
Hardware Options		ORP+pH+Temp+Doser	pH+Temp+Doser
Selectable Chlorine Mode	Inverter Mode 1 (0-40%)	√	-
	Inverter Mode 2 (0-100%)		
	Inverter Mode 3 (0-120%)		
	Manual Mode		
	ON/OFF Mode 1 (40%)	-	√
	ON/OFF Mode 2 (100%)		
	ON/OFF Mode 3 (120%)		

	Manual Mode		
--	-------------	--	--

**Chlorine Mode Selection:**

- Tap  and hold for 3 seconds enter the mode of unlock which display all buttons.
- Tap  enter the home screen.
- Tap  enter chlorine mode selection.
- Tap  to select modes  /  /  / 
- Tap  to confirm your selection, and go to next step

The HOME screen of each chlorine mode is shown as follows:

**Premium -Inverter Mode**

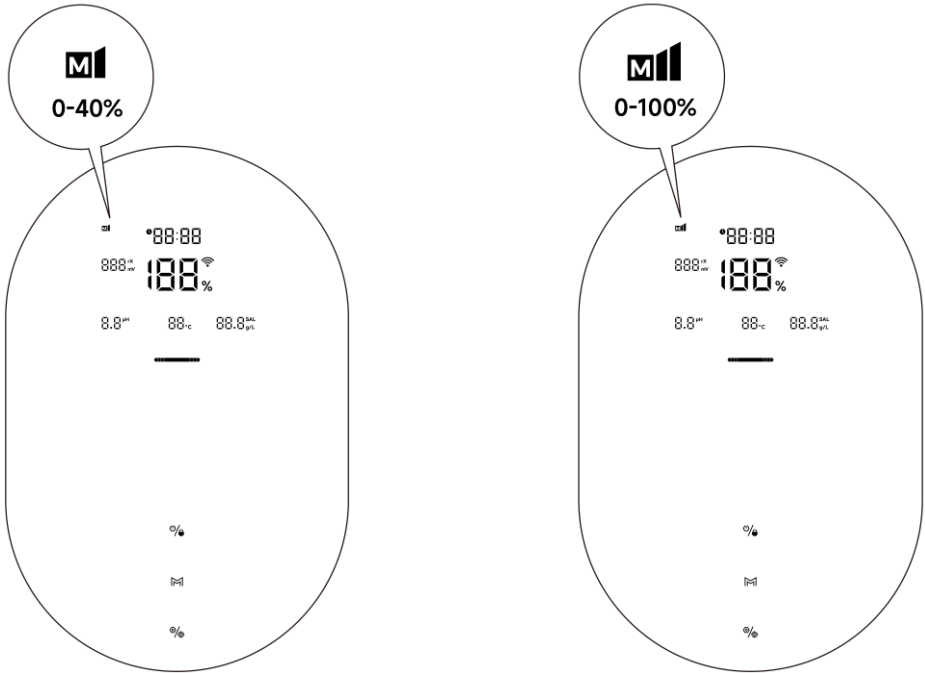

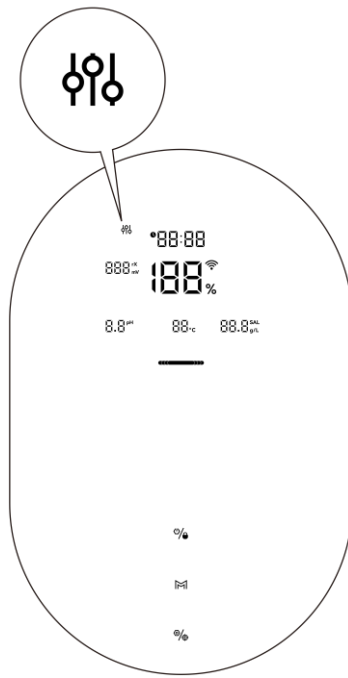
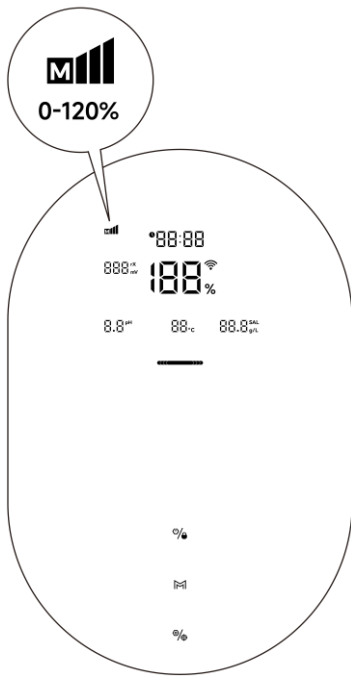

**Medium ON/OFF Model**

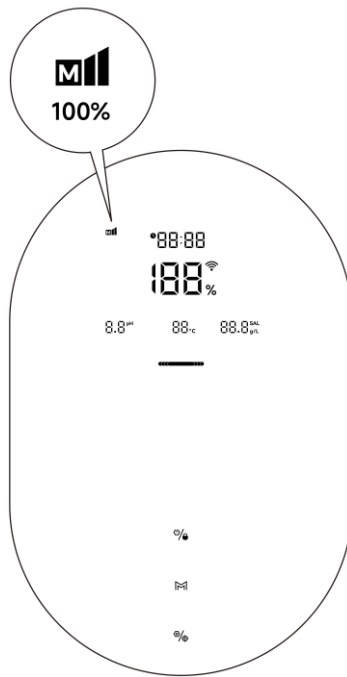
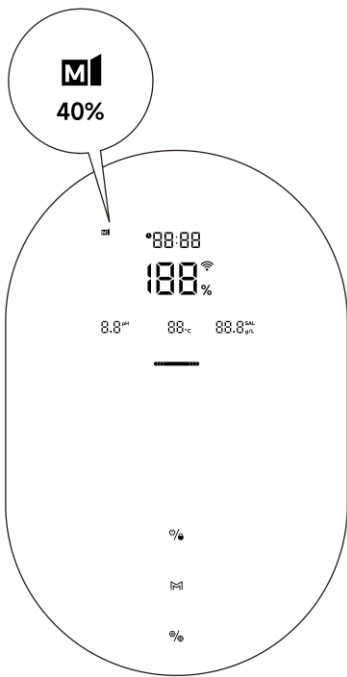









### 4.3 LED Indicator Introduction

The LED Indicator of each status is shown as follows:

Status		LED Indicator
Real-time Water quality Display	Prefect	Blue
	Good	Yellow
	Wait (ORP /PH readings abnormal)	Red
Chlorine production	Chlorine producing	1. Displays real-time water quality 2.Keep flashing in a regular frequency, base on the Real-time Chlorine production (%)
	Stand by	Displays real-time water quality, LED keeps on.
	Chlorine production is stopped due to errors	Displays real-time water quality, LED keeps on.
Calibration	ORP Calibration (Blue)	1. In operation: Light flashes 2.Completed: Light keep on and the beeper sounds 3. Calibration Failed: Light disappears
	PH 7.0 Calibration (Yellow)	
	PH 10.0 Calibration (Red)	
Screen Locked		1. Keep displaying real-time water quality 2. Screen brightness reduced to 50%





## 4.4 Basic Commands and Functions

Command Keys	Function
	<ol style="list-style-type: none"> <li><b>Power on:</b> Hold for 3 seconds.</li> <li><b>Home Screen:</b> Tap  after the first step.</li> <li><b>Power OFF:</b> Tap on home screen.</li> <li><b>Lock/Unlock:</b> Hold for 3 seconds.</li> </ol> <p><b>Note:</b> The auto lock function will be activated after 2 minutes without any operation.</p>
	<ol style="list-style-type: none"> <li><b>Activate TURBO mode:</b> Hold for 3 seconds on home screen.</li> <li><b>Exit TURBO mode:</b> Hold for 3 seconds</li> </ol>
	<ol style="list-style-type: none"> <li><b>Setting Menu:</b> Tap  to enter, tap  go to next step.</li> <li><b>Calibration Menu:</b> Hold  to enter.</li> </ol>





### 4.4.1 Start Up/ First-time Initialization

After completing the installation and switched on the chlorinator, it will automatically enter the main interface. Rely on the Chlorinator Model and the Chlorine Production Mode you select, please finish ① **Calibration Process Steps** , ② **Settings Process Steps** and ③ **Doser Check Steps** as follows:

#### ① Calibration Process Steps



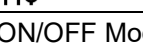



Chlorinator Model	Chlorine Mode 	1-Calibration Process Steps			
		ORP Calibration	pH Calibration	Pool Size Setting	Local Time
Premium	Inverter Mode 	√	√	√	√
	Manual Mode 	-	-	√	√
Medium	ON/OFF Mode 	-	√	√	√
	Manual Mode 	-	-	√	√

#### ② Setting Process Steps

Chlorinator Model	Chlorine Mode 	2-Setting Process Steps				
		ORP Setpoint	pH Setpoint	Chlorine Production	pH Dosing Volume	Timer
Premium	Inverter Mode 	√	√	-	-	√
	Manual Mode 	-	-	√	√	√
Medium	ON/OFF Mode 	-	√	-	-	√
	Manual Mode 	-	-	√	√	√

### ③ Doser Check Steps

To check the Doser works properly or not, the steps are as follows:

- ① Make sure the Doser hoses and PE acid tubes are connected and fitted tightly.
- ② Check the acid tank's fluid level, make sure PE acid tube is connected to suction valve in the tank.
- ③ Tap , turn off the Chlorinator(**Power OFF**).
- ④ Hold the place of  and , enter the Doser Checking Page, the doser will rotate for 3 minutes automatically, for user to check its rotation and the sound. Tap  to stop rotating, Tap  to start rotating again.
- ⑤ Keep the doser rotating for 2-3 minutes, until the acid solution is fulfilled in PE acid tubes and peristaltic tube.
- ⑥ Acid solution is pushed out to pool water through the Doser tube, the Doser is ready.
- ⑦ Hold , turn back to the home screen..
- ⑧ Tap , turn on the Chlorinator(**Power ON**).

### 4.4.2 Settings Menu

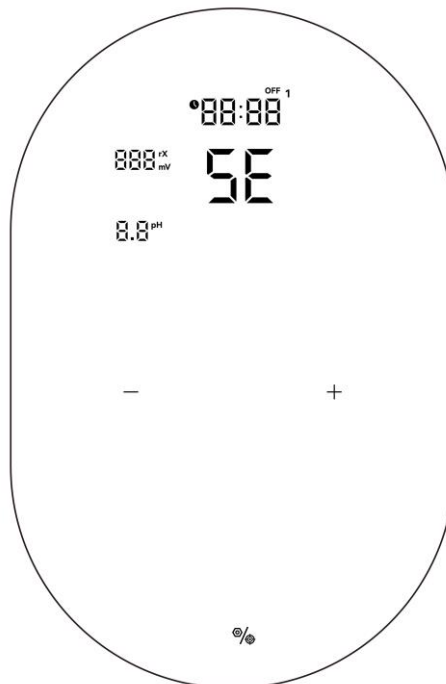

Tap  to Enter **Settings Menu**.

#### ① ORP Setpoint Setting (Inverter mode / /

- The default digit display on the pad screen is “700mV”.
- When the number “700” is blinking, it can be turned from 200 to 850 mV, in increments of 1, by

tapping  $+$  or  $-$  .

- Confirm the ORP setpoint setting by tapping  , and enter the next step: pH Setpoint setting.



## ② pH Setpoint Setting (Inverter Mode & ON/OFF Mode )

- The default digit display on the pad screen is “7.4”.
- When the number “7.4” is blinking, it can be turned from 6.5 to 8.0, in increments of 0.1, by tapping  $+$  or  $-$  .
- Tap  to confirm and enter next step.

**Note:** If pool volume is “SIZE 0 m<sup>3</sup>”, **Alarm A1, E2 (pH Setpoint not Reached)** will be turned off.

## ③ Timer Setting

- There are 2 timers in total, named **1** and **2**.
- For Each timer, When the **TIMER ON** is Blinking, tap  $+$  or  $-$  to select **TIMER ON** or **TIMER OFF** , which means switching on or off the single timer .

Step 1	Step 2
Select <b>TIMER ON</b>	<p>①When <b>TIMER ON</b> and <b>1</b> lights up, set hours of the first timer by tapping <math>+</math> and <math>-</math> , save the parameter by tapping  , then set and save minutes in the same way.</p> <p>②When <b>TIMER ON</b> setting finished, <b>TIMER OFF</b> light up, set the end time of the <b>1</b> timer in the same way.</p> <p>③tap  save timer <b>1</b> and skip to next timer settings <b>2</b>.</p>
Select <b>TIMER OFF</b>	<p>① No need to set the timer <b>1</b>, tap  and skip to timer <b>2</b>.</p>

- Tapping  to Confirm Timer settings and return to home screen.

## 2、Manual Mode:

### ① Chlorine Production Setting

- The default digit display on the pad screen is “100%”.
- When the number “100” is blinking, it can be turned from 120 to 0, in increments of 5, by tapping  $+$  or  $-$  . Hold the button can accelerate the tuning speed.



- Tap  to next step.

## ② pH Dosing Volume Setting

- pH Dosing Volume Setting: range 0-99900 mL/day
- The default digit display on the pad screen is “0-9990”
- The default digit display on the pad screen is “60”, it means the real pH Dosing Volume is 600 ml/d.
- Tap  to confirm and enter next step.



## ④ Timer Setting

- There are 2 timers totally, **1** and **2**.
- For Each timer, tap  $+$  or  $-$  to select **TIMER ON** or **TIMER OFF**, which means switching on or off the single timer.

Step 1	Step 2
Select <b>TIMER ON</b>	<p>① When <b>TIMER ON</b> and <b>1</b> lights up, set hours of the first timer by tapping <math>+</math> and <math>-</math>, save the parameter by tapping , then set and save minutes in the same way.</p> <p>② When <b>TIMER ON</b> setting finished, <b>TIMER OFF</b> light up, set the end time of the <b>1</b> timer in the same way.</p> <p>③ tap  save timer <b>1</b> and skip to next timer settings <b>2</b>.</p>
Select <b>TIMER OFF</b>	<p>③ No need to set the timer <b>1</b>, tap  and skip to timer <b>2</b>.</p>

- Tapping  to Confirm Timers setting and return to home screen.

### NOTE:

- ① During the settings and calibration process, all values are set by tapping  $+$  and  $-$ ;
- ② Users can return to home screen at any point by holding  for 3 seconds, or skip any step by tapping .

## 4.4.3 Recommended Settings

Tap Setting  to enter settings in accordance with following order:



- 1) ORP Target Value setting: range 200-850mV (Inverter Mode)
  - Sug'td ORP Winter setting: ORP 650mV.

- Sug'td ORP summer setting:ORP700mV.
  - If you have other free chlorine monitoring instrument., adjust your pool water (Free chlorine 1.0 to 3.0 ppm), then look at ORP value on the chlorinator screen and memorize this level as the setpoint.
- 2) pH Target Setting: range 6.5-8.0, the recommended setpoint is in:7.2~7.6
  - 3) Chlorine Production: range 0-120% **(Manual Mode)**.
  - 4) pH Dosing Volume Setting: range 0-99900mL/day **(Only Manual Mode)**.  
Hydrochloric Acid:  $\leq 12.5\%$  concentration.
  - 5) Timers setting: range 0:00-24:00 (24hr clock).

#### 4.4.4 Calibration Menu

On the home screen, Hold  to enter Calibration Menu.

##### ① ORP Calibration( Inverter Mode)





- Before the calibration, choose Inverter Mode  on the home screen
- On the home screen , Tap  and hold for 3 seconds to enter Calibration Menu.
- When the default digit display “ORP 468 mV” and the LED indicator is flashing on the screen.
- Place ORP probe into 468mV buffer solution, make sure the head of the probe is totally immersed.
- Calibration is completed when the beeper sounds.
- Tap  to next step.



**NOTE:**

- This step can also be skipped by tapping .
- ORP calibration values range from 200-700, step size is 1.
- If the ORP probe stays unsoaked by the buffer solution for 30 seconds or is soaked in the wrong solution, the indicator will keep flashing until the probe is handled properly.

**⑤ pH 7.0 and pH 10.0 Calibration**

- Before the calibration, choose **Inverter or ON/OFF Mode**  on the home screen.
- On the home screen, Tap  and hold for 3 seconds enter the Calibration Menu, Tap  skip to pH 7.0 and pH 10.0 Calibration.
- When the digit display “pH 7.0” and the indicator is flashing on the pad screen, place pH probe into the PH7.0 buffer solution. Make sure the head of the probe is totally immersed.
- Calibration is completed when the beeper sounds.
- Tap  to the next step, pH 10.0 calibration. (Remember to clean the pH probe before pH10.0 calibration).
- The entire process of pH 10.0 calibration is the same with pH 7.0 calibration.
- Tap  to next step: Pool volume setting.

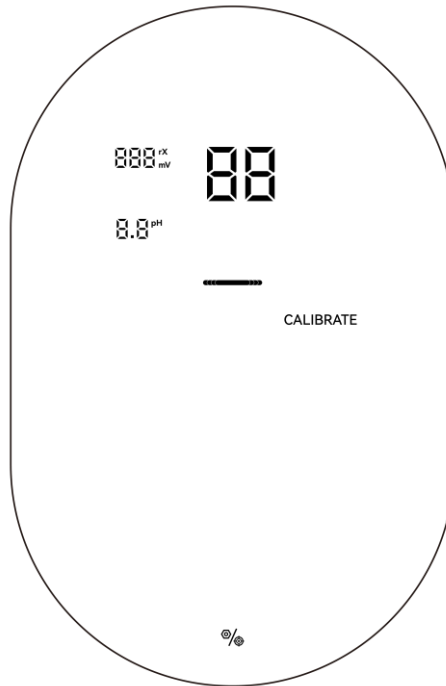

**NOTE:**

- This step can also be skipped by tapping the setting button .
- If the pH probe stays unsoaked by the buffer solution for 30 seconds or is soaked in the wrong solution, LCD light with red dynamic display until the probe is correctly initiated.
- Before calibrating or replacing the probe, isolate the electrolytic cell by closing the IN/OUT flow valves.



**② Pool Volume**

- The default digit display on the pad screen is “SIZE 40 m<sup>3</sup>” as follows.
- When the number is blinking, it can be turned from 5 to 150 m<sup>3</sup>, in increments of 5, by tapping  $+$  or  $-$ .
- Confirm the pool volume setting by tapping , and enter the next step: Local time setting.

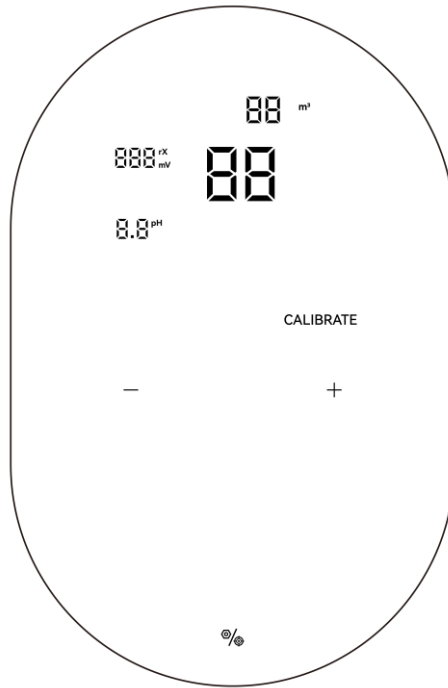
**Note:** If pool volume is “SIZE 0 m<sup>3</sup>”, **Alarm A1, E2 (pH Setpoint not Reached)** will be turned off.



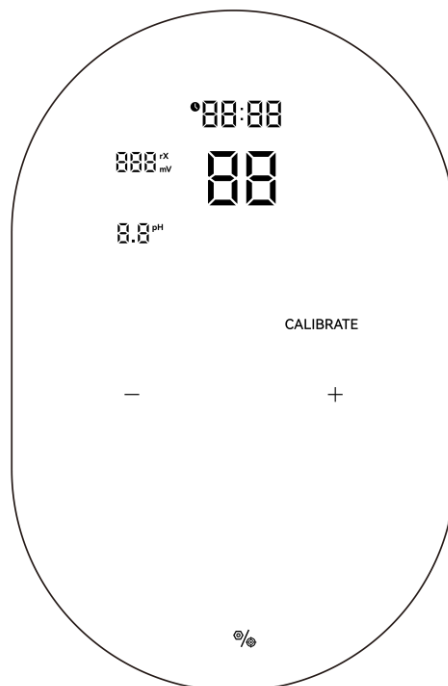

### ③ Local Time Settings and Calibration

- If the chlorinator is off-line, When the local time is blinking, Please tap **+** to select **【on】** and tap  to set the local time numbers.
- Set hours of the local time by tapping **+** and **-**, save the parameter by tapping , then set and save minutes in the same way.
- If the chlorinator is connected to the network, the local time can be automatically calibrated through the network.



#### 4.4.5 TURBO /Winter/Cover Performance

##### ① TURBO

- On home screen, tap  and hold on 3 seconds to enter turbo mode
- The device will run at default 120% power for 24 hours regardless of the ORP readings and/or setpoint values. The real-time production and turbo countdown will be displayed.
- After 24 hours turbo mode, the Chlorine Production Mode will turn back to the status before turbo mode is on.
- Tap  and hold for 3 seconds to exit Turbo mode.



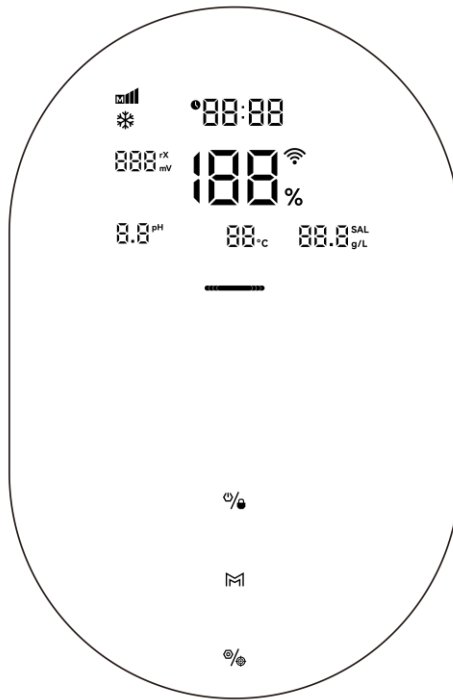

##### ③ Winter mode

- When the water temperature is lower than 10°C, low chlorine production will be activated automatically, with  icon displayed on the screen.
- If the current chlorine production percentage is higher than 20%, the chlorine production will reduce to 20%; if it is lower than 20%, it will remain unchanged.
- When the water temperature is below 5°C, the chlorine production will stop, E5 on.

















① **Pool Cover mode**

- When the pool cover is detected, low chlorine production will be activated automatically, with  icon displayed on the screen.
- If the current chlorine production percentage is higher than 20%, the chlorine production will reduce to 20%; if the current chlorine production percentage is lower than 20%, it will remain unchanged.
- When the pool cover is not detected, the Cover is exited and the  is not displayed. Normal electrolysis is resumed.



## 4.5 External Device

### 4.5.1 VS Pump







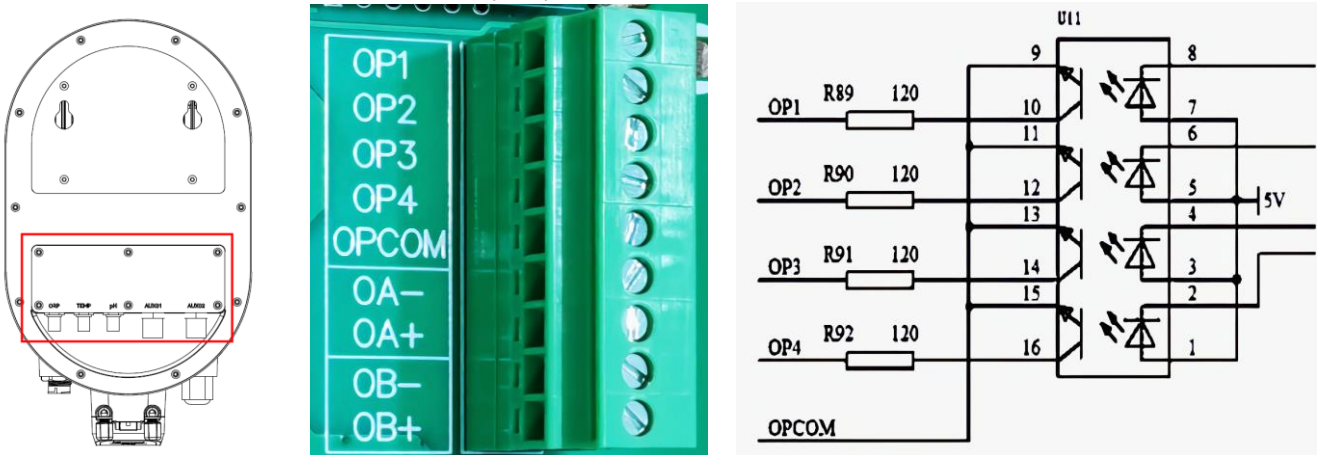

- ① Tap  and hold for 3 seconds enter the mode of unlock which display all buttons, then tap  enter the home screen.
- ② Hold the  and  for 3 seconds to enter the device activation interface and select the equipment to be activated (default item 1 is the water pump equipment).
- ③ Tap  to deactivate the pump control function, the  flashes; tap  to activate the pump control function, the  is always bright.
- ④ Tap  to enter the external device activation interface; tap  and hold on for 3 seconds to exit the device activation interface and enter the normal operation interface.
- ⑤ In the normal operation state, and the pump control function has been activated, the  is always on, and tap  can control the pump to run in OFF, SP1 , SP2  and SP3  modes.

**Note:**





- The AUX1 terminal diagram of the inverter water pump is as shown below.
- Use tools to remove the acquisition board in the red frame of the host rear cover.
- Water pump interface: OP1, OP2, OP3, OP4, OPCOM respectively control the off, first SP, second SP, and third SP of the inverter water pump.



### 4.5.2 External Device1&2

- ① Tap  and hold for 3 seconds enter the mode of unlock which display all buttons, then tap  enter the home screen.
- ② Hold  and  for 3 seconds to enter the device activation interface
- ③ Default item 1 is the water pump equipment, tap  to enter the external device activation interface.
- ④ Tap  to deactivate the control function of device 1, then the  flashing, tap  to

activate the control function of device 1, then the  of device 1 is always lit.

- ⑤ Tap  to enter device 2 activation, The control of device 2 can refer to the operation of device 1.
- ⑥ Tap  and hold on for 3 seconds to exit the device activation interface and enter the normal operation interface.
- ⑦ In the normal operating state, and the control function of device 1 has been activated, the control button icon  of device 1 is always on, and the device 1 can be controlled to start and stop by tap , and the corresponding icon of the LCD screen is on and off at the same time, the control of device 2 can refer to the operation of device 1.

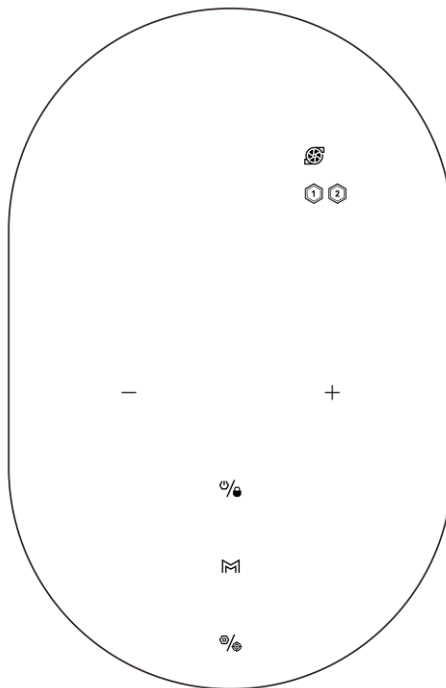

**NOTE:**

- External device 1 & 2 wirings are similar to 4.4.1.
- OA+ & OA-, OB+ & OB- , respectively control the signal on/off of external device 1 and external device 2.

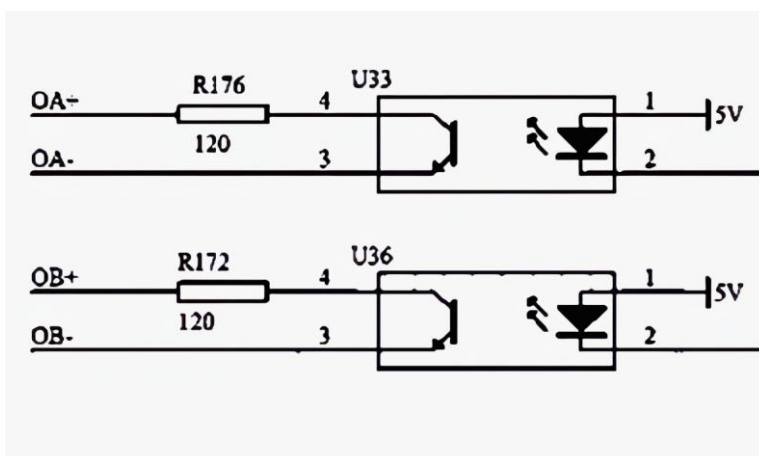



**4.5.3 Pump Control & 485 COM**

- ① The AUX2 terminal diagram of the inverter water pump is as shown below.

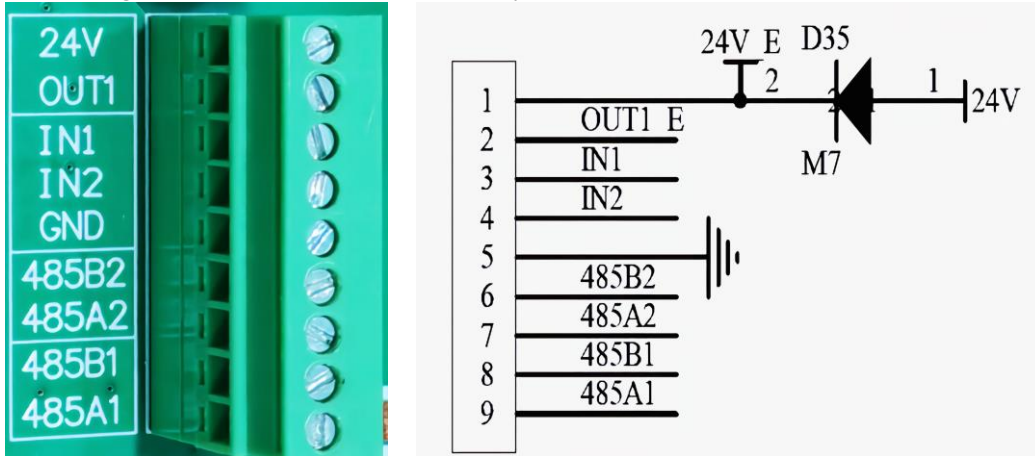
- ② Use tools to remove the acquisition board in the red frame of the host rear cover.
- ③ IN1 is the access point for the pool cover signal, short-circuited with GND for input.
- ④ 485A2 and 485B2 are a group of 485 signal circuits, which communicate with the central control as a slave.
- ⑤ This terminal is a non-isolated low-voltage signal and cannot be connected to a high-voltage system. The remaining interfaces are reserved for backup.



## 4.6 Combinations and Operation

Combinations	Function
Tap  , then hold $+$ and $-$ for 3 second	Restore factory settings
Tap  , then hold  and $+$ for 3 second	Enter network configuration screen

### 4.6.1 Automatic Reminder for Probe Calibration (Cb)

In home screen, Tap , turn off the Chlorinator(**Power OFF**).

Then hold  and  $-$ , to enter Automatic Reminder for Probe Calibration (Cb) .

Tap  $+$  or  $-$  to choose the Probe Calibration Reminder Mode (**On or Off**) .



Then tap  to save and return home screen (**Power OFF**).

Hold  to turn on the Chlorinator again(**Power On**).



Probe Calibration Reminder Mode	Description	Note
OFF (Blinking)	Reminder is turned off. (Default)	
ON (Light keeps on)	<ul style="list-style-type: none"> <li>● Reminder is turned on.</li> <li>● The Chlorinator control unit will show <b>Probe Calibration hint</b> automatically every 180 days</li> <li>● Once the Probe Calibration is finished, the countdown(180 days) will be reset.</li> </ul>	It is very important to carry out a calibration of ORP probe and pH probe at the beginning of each season of use when returning to service, and after each probe replacement.

## 4.6.2 Electrodes Cleaning Time Setting

In home screen, Tap  , turn off the Chlorinator(**Power OFF**).

Hold  and  , to enter Automatic Reminder for Probe Calibration (Cb) .

Tap  skip to **Electrodes Cleaning Time Setting**.



Tap  or  to choose 2/4/6h, 3 options (**default: 4h**) .

Then tap  to save and return home screen (**Power OFF**).

Hold  to turn on the Chlorinator again(**Power On**).



## 4.6.3 Restore Factory Settings

After the Chlorinator power supply is cut off and recovered, settings will be restored to default parameters, need to be reset.

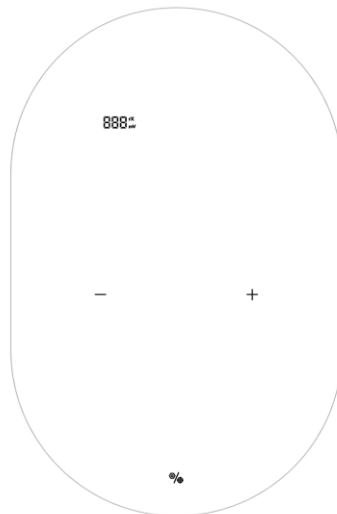
Tap  on home screen, then hold  and  simultaneously for 3 second, hearing the beeper, the chlorinator is restored to factory settings, and automatically will start initialization process as in 4.3.1.



## 4.6.4 Network Configuration

- ① Enter Network Configuration screen by tapping  on home screen, then hold  and  simultaneously for 3 seconds, an intermittent buzz will be heard.
- ② During network configuration process, the chlorinator remains operating with the previous configuration.
- ③ The beeper stops when network configuration is complete.  
\*: For details, please check 9.1.2.

## 5 Salt Replenishment



**The chlorinator must remain OFF during this operation and until the additive is completely dissolved. Operating the chlorinator with non-dissolved salt could irreversibly damage the cell and the power supply, and lead to a void of the warranty.**

Calculate the volume of the swimming pool and add 1 to 2 Kg of salt per cubic meter. The suggested salinity is 1 g/L. Make sure the chlorinator is disconnected during the whole salt adding process and turn on the filtration system for at least 24 hours, allowing the salt to dissolve completely.



**For any new pool builds please wait for four weeks before adding salt into any recently cement coated pool or discuss this with your pool builder.**

The salt dissolving process can be accelerated using the pool cleaner. Check the salt concentration is between 1 and 2 kg/m<sup>3</sup> using a kit from a specialized pool shop.

The salt concentration may reduce over time due to rain or other periodic freshwater contributions (topping up, backwashing, etc.). Whenever the salt concentration needs to be corrected, pour salt as close as possible to the return lines. Never pour salt in the skimmers or near the drain inlet.

# 6 Maintenance

## 6.1 Cleaning the Electrodes

The smart polarity inversion system is designed to prevent the electrode plates from corrosion and scaling (Default setting = 4 hours). However, periodic cleaning may be required when the water hardness is too high.

The cleaning process is listed as follows:

- ① Turn off the chlorinator and the filtering, close the isolation valves, and ensure power is disconnected at the isolating switch.
- ② Place the cell backwards and fill it with a cleaning solution so that the electrode plates are immersed.  
  
Do not allow the cell cap assembly to be immersed.
- ③ Leave the cleaning solution to dissolve the scale deposit for about 15 minutes. Dispose of the cleaning solution at an approved waste recycling site, never pour into the rainwater drainage system or into the sewers.
- ④ Rinse the electrode using clean water and put it back on the cell fixture collar (there is an alignment mark).
- ⑤ Refit the tightening ring and reconnect the cell cable. Open the isolation valves and restart the filtering and chlorinator.
- ⑥ If you do not use a commercially available cleaning solution, you can manufacture it yourself by carefully mixing 1 volume of hydrochloric acid with 9 volumes of water (Warning: always pour the acid into the water and not the opposite and wear suitable protective equipment!).
- ⑦ Make sure that the setting of the polarity inversion cycles is adapted to the pool water hardness.

## 6.2 Maintenance of the ORP Probe (Premium)

### 6.2.1 Cleaning the Probe

Under any circumstance, every 6 months cleaning is always advisable. Generally, impurities and grease caught on electrodes may also result in measurement errors.

The cleaning steps are as follows:

- ① Turn off the chlorinator, close flow isolating valve, and unscrew the ORP probe from the holder.
- ② Thoroughly clean the probe in pure, preferably distilled water. Carefully shake the probe to remove the water. Use a cotton or a paper napkin if necessary.
- ③ Turn on the control unit, insert the probe into standard calibration solution (default 468mV) and complete the calibration process.
- ④ **It is very important to carry out a calibration of the ORP probe at the beginning of each season of use when returning to service, and after each probe replacement.**

### 6.2.2 Storage

In case of pools being shut down during the winter season, take the probe out of the cell and store it at temperature from +5 to +30 °C in the probe storage cap filled with a storage solution.

Other storage methods are not recommended.

**NOTE:** Never leave the probe in the open air. If the probe has been dry for a time, it can be regenerated using the standard calibration solution.

## 6.3 Maintenance of the pH Probe

### 6.3.1 Maintenance

It is recommended to clean and check the probe every 6 months. Generally, impurities and grease caught on electrodes may also result in measurement errors.

The cleaning steps are as follows:

- ① Stir the probe in a glass of water in which a spoonful of detergent has been dissolved.
- ② Wash it under the tap and leave it for a few hours in a glass of water in which 1 cm<sup>3</sup> of hydrochloric acid has been added.
- ③ Thoroughly clean the probe in pure, shake the probe to remove the water. Use a cotton or a paper napkin if necessary.
- ④ Recalibrate the probe again.
- ⑤ **It is necessary to carry out a calibration of the pH probe at the beginning of each season of use when returning to service, and after each probe replacement.**

### 6.3.2 Storage

In case of pools being shut down during the winter season, take the probe out of the cell and store it at temperature from +5 to +30 °C in the probe storage bin filled with a storage solution.

Other storage methods are not recommended.







#### NOTE:

- If well maintained, a probe can last for two or three years. When the probe is exposed in air, the original cap should be placed, or it should be submerged in a glass of water.
- If a probe has been left to dry, it can be regenerated by leaving it for 12 hours in a glass of water, preferably adding a few drops of hydrochloric acid.

## 6.4 Maintenance of the Doser

### 4.5.1 Maintenance

To check the Doser works properly or not, the steps are as follows:

- ① Make sure the Doser hoses and PE acid tubes are connected and fitted tightly.
- ② Check the acid tank's fluid level, make sure PE acid tube is connected to suction valve in the tank.
- ③ Tap , turn off the Chlorinator(Power OFF).
- ④ Hold the place of  and , enter the Doser Checking Page, the doser will rotate for 3 minutes automatically, to check its rotation and the sound. Tap  to stop rotating, Tap  start rotating again.
- ⑤ Hold , turn back to the home screen..
- ⑥ Tap , turn on the Chlorinator(Power ON).

#### NOTE:

- **Inverter Mode and ON/OFF Mode:** the Doser will regularly rotates every 3 minutes, with 90ml acid injection each rotation (30s duration).
- **Manual Mode:** the Doser will rotate according to **pH Dosing Volume Setting**.

- The doser roller will rotate for 30 seconds and injecting around 100ml acid each time. Injection frequency is based on pH dosing volume setting (24hours) and the chlorinator operate time in ever 24hours

e.g. :

If daily pH dosing volume setting=6000 ml, chlorinator timer is set to work for 12h/day.

Actually, pH dosing volume = 30000ml Injection interval  $\approx$  144s

- When the actual pH value is equal to or lower than pH setpoint, the Doser roller pauses rotating.
- When pH probe detection fails or E5 (no flow) alarm displays, the Doser roller will stop spinning.

## 7 Winterizing and Low Temp Protection

The chlorinator has low temperature protection to limit chlorine production (%) under poor operating conditions such as cold water (winter).

Active winterizing = filtering and chlorinator operational in winter:

Passive winterizing = lower water level and drained piping: leave the electrode plates dry in its cell with its isolation valves- open.

Low Temperature Protection:

- Water temp above 10°C: Chlorinator running in the preset mode
- 5°C<Water temp <10°C: Chlorinator running in the winter mode, production capped at 20%.
- Water temp below 5°C: Electrolysis off. E5 Alarm is on
- After E5 Alarm is on , Water temp <6°C: electrolysis keeps off.
- 6°C<Water temp <10°C: Chlorinator running, production capped at 20%, E5 off.
- Water temp > 11°C: Chlorinator running in the preset mode.

**Note:**

- Temperature sensor must be installed, if you need Low temperature protection.

## 8 Overheat Protection

Overheat protection will be activated when the power pack temperature inside the main control unit is higher or equal to 70 °C.

High Temperature (Power pack)	$70^{\circ}\text{C} \leq \text{Temperature} \leq 80^{\circ}\text{C}$	A. Electrolytic output reduce base on the real time Temperature Electrolytic output $\geq$ 20%
Over Temperature (Power pack)	Temperature $> 80^{\circ}\text{C}$	A. E4 occurred and stop electrolysis B. Temperature $< 69^{\circ}\text{C}$ , E4 off, electrolysis starts again.

## 9 Wi-Fi Instruction

### 9.1 Start-Up



### 9.1.1 Download App on Smartphone

"InverGo" app is available on App Store and Google Play.

### 9.1.2 Networking Configuration

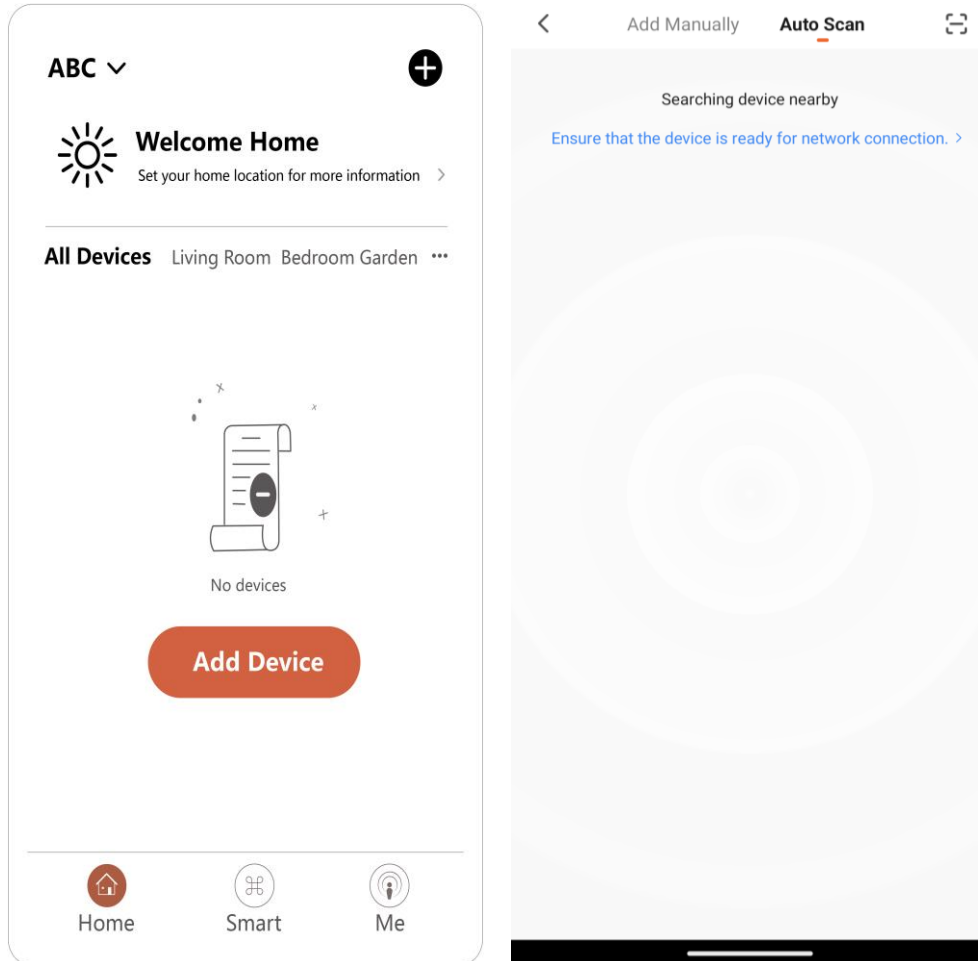
Turn on your location services, Wi-Fi and Bluetooth, enter the "InverGo" App, tap the "+" icon in the top right corner of the home page, and then Tap on "Auto Scan" to start searching for nearby devices.



When Control Unit is on home screen, tap  to enter settings, hold  and  for 3 seconds, when an intermittent beep occurs, and enters network connection mode.

When your phone finds the Control Unit, it will be displayed on your phone. Tap "Next", input the hotspot password, and tap "Next". Then the device will be automatically installed in the App. The mobile phones and devices need to be connected to the same hotspot.

When installation is finished, the device will beeper 3 times and on the App, it will be shown as added.

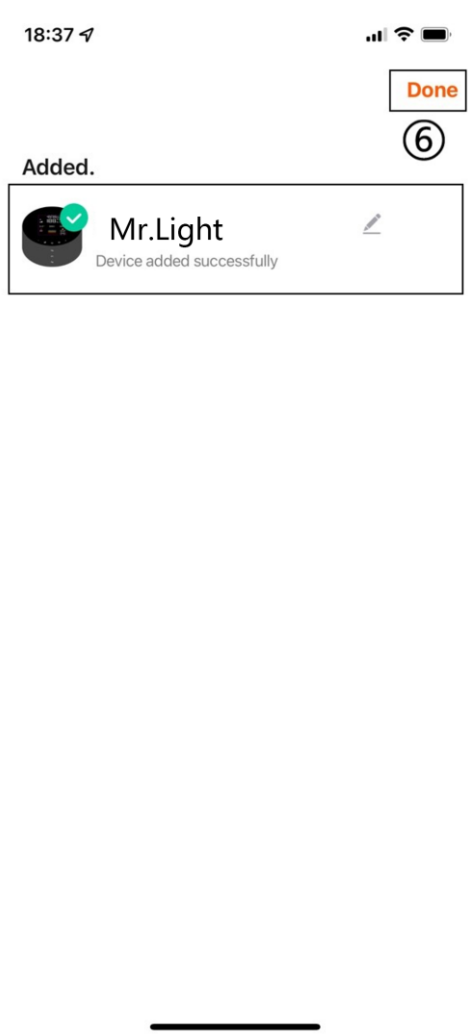
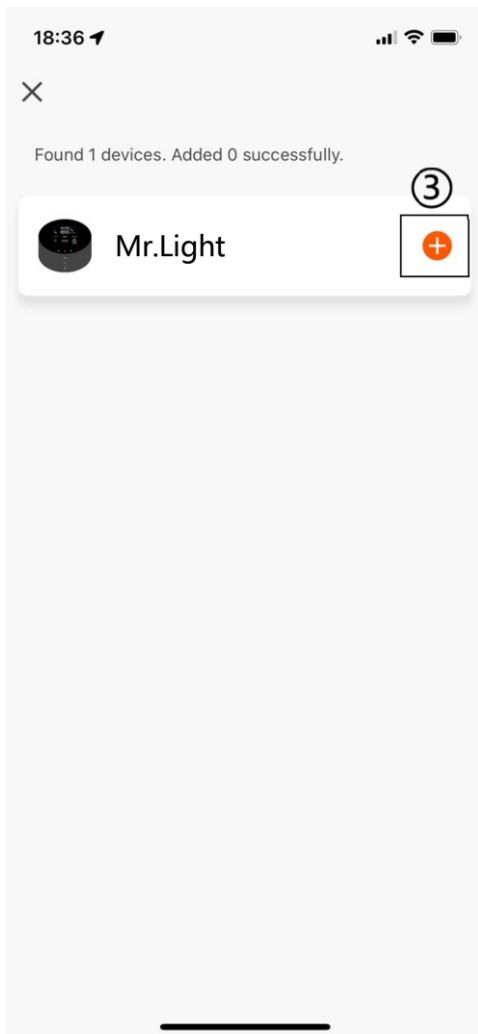

## 9.2 Device Sharing

Enter the app Settings, tap “Share Device”, and add the mobile number of the corresponding person being shared. By downloading the “InverGo” app, the user being shared can view the device's information simultaneously.

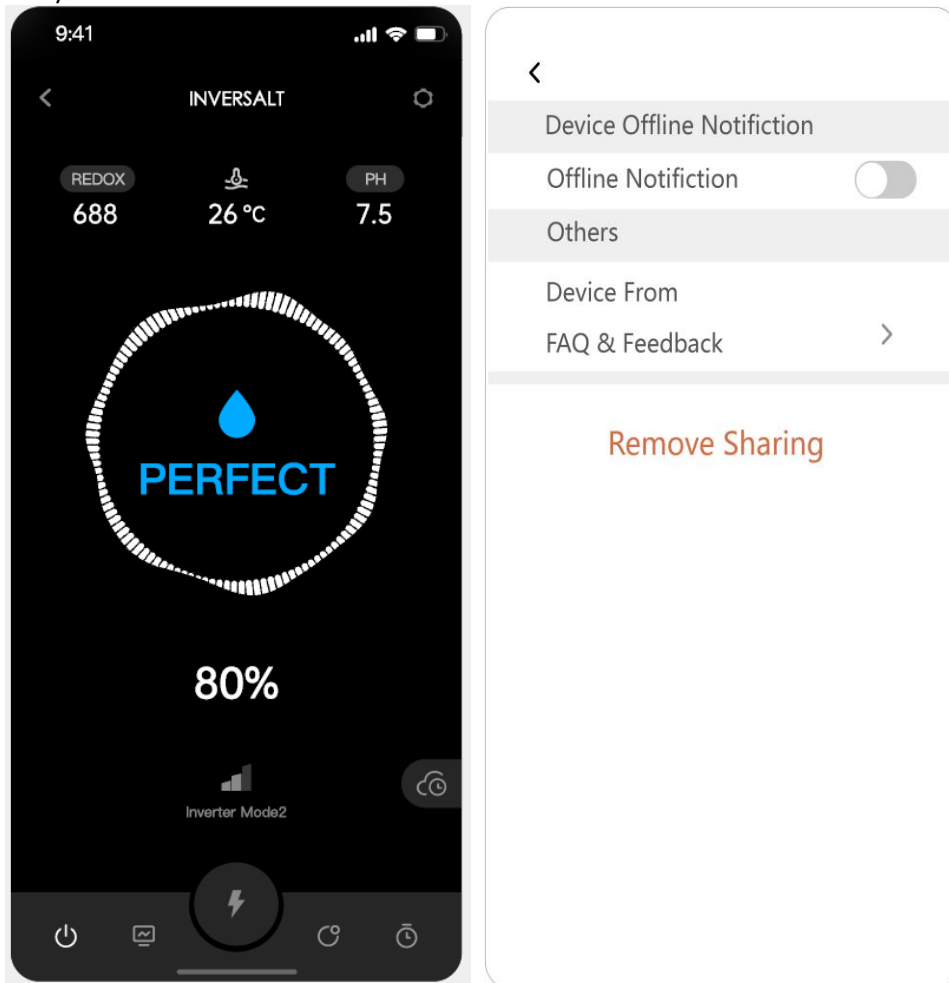

# 10 Error Code and Solution

Error Code	Effect	Trigger	Elimination	Remark
<b>ACID TANK (A1)</b>	Indicators lights up, electrolysis process continues.	<ol style="list-style-type: none"> <li>1. Run out of acid.</li> <li>2. Have been adding acid for a long time but failed to reach targeted pH value.               <ol style="list-style-type: none"> <li>a. Alarm after 6 hours when <math>\text{pool} &lt; 40\text{m}^3</math>.</li> <li>b. Alarm after 12 hours when <math>40\text{m}^3 \leq \text{pool} &lt; 70\text{m}^3</math>.</li> <li>c. Alarm after 18 hours when <math>\text{pool} \geq 70\text{m}^3</math>.</li> </ol> </li> </ol>	<ol style="list-style-type: none"> <li>1. Restart the chlorinator.</li> <li>2. Automatically resume normal operation, when setting the pH setpoints equals to previous reading.</li> </ol>	<ol style="list-style-type: none"> <li>1. Replenish the acid tank.</li> <li>2. Check for leakage of the whole dosing system.</li> <li>3. Try the following steps:               <ul style="list-style-type: none"> <li>● Check pH probe connections</li> <li>● Clean the probe</li> <li>● Calibrate the probe and test pH value</li> <li>● Replace probe</li> </ul> </li> <li>4. If pool volume is set to <math>0\text{ m}^3</math>, A1 will be turned off.</li> </ol>
<b>ADD SALT (A2)</b>	Indicators light up, electrolysis process continues.	<ol style="list-style-type: none"> <li>1. Pool salinity below 750ppm for more than 1h</li> <li>2. Water temperature too low</li> <li>3. Electrodes malfunction</li> </ol>	Automatically resume normal operation, when salinity the higher than minimum threshold.	<ol style="list-style-type: none"> <li>1. Replenish the salt up to recommended level(1000-2000ppm).</li> <li>2. Check the water temperature.</li> <li>3. Check the cell for excessive scaling or coating loss.</li> </ol>
<b>NO FLOW (A3)</b>	Indicators light up, electrolysis process continues.	<ol style="list-style-type: none"> <li>1. Flow status detected is "OFF"</li> </ol>	Automatically resume normal operation, when Flow switch "ON" status is detected.	<p>Insufficient water flow might be caused by:</p> <ol style="list-style-type: none"> <li>1. Filtration pump stops.</li> <li>2. Water valve is closed</li> <li>3. Other possible reasons.</li> </ol>
<b>E1 Power Supply Abnormal</b>	Pause electrolysis process	<ol style="list-style-type: none"> <li>1. Electrodes disconnected or wrongly connected.</li> <li>2. Electrodes malfunction.</li> <li>3. Internal electrical components malfunction.</li> </ol>	Automatically resume normal operation, when the DC output recovers back to normal range.	<ol style="list-style-type: none"> <li>1. Check electrodes connection.</li> <li>2. Check the cell for excessive scaling or coating loss.</li> <li>3. Please contact the After-Sales Center.</li> </ol>
<b>E2 pH Setpoint not Reached</b>	Pause the acid adding process	<p>pH readings failed to reach setpoints.</p> <ol style="list-style-type: none"> <li>a. Alarm after 24 hours when <math>\text{pool size} &lt; 40\text{m}^3</math>.</li> <li>b. Alarm after 48 hours when <math>40\text{m}^3 \leq \text{pool size} &lt; 70\text{m}^3</math></li> <li>c. Alarm after 72 hours when <math>\text{pool} \geq 70\text{m}^3</math>.</li> </ol>	<ol style="list-style-type: none"> <li>1. Restart the chlorinator.</li> <li>2. Automatically resume normal operation, when setting the pH setpoints equals to previous reading.</li> </ol>	<ol style="list-style-type: none"> <li>1. Test pH with other equipment</li> <li>2. Balance the pH level by adding extra chemicals.</li> <li>3. Try the following in order:               <ul style="list-style-type: none"> <li>- Check pH probe connections.</li> <li>- Clean the probe.</li> <li>- Calibrate the probe and test PH again.</li> <li>- Replace probe.</li> </ul> </li> <li>4. If pool volume is set to <math>0\text{ m}^3</math>, E2 will be turned off.</li> </ol>

E4 Control Unit Overheat	Pause electrolysis process	1. The Control Unit is over 70°C, Salt Chlorinator automatically reduces operating speed. 2. Stop operating when the internal of control unit is over 80°C.	1. Automatically resume normal operation, when the Control Unit is below 69°C	1.Be careful not to install the Salt Chlorinator in a position exposed to direct sunlight, install shade or move the Salt Chlorinator to a sheltered position.
E5 Low Temp in Cell	Reduce electrolysis process speed	1. Water temperature is below 10°C, Salt Chlorinator automatically reduces operating speed. 2. Stop operating when water temperature is below 5°C.	1. When the temperature is over 6°C, E5 is cleared and Limit to 20%.  2. Automatically resume normal operation, when water temperature is raised to over 11°C.	1.Enter Winter Mode. 2. Use heating pump to warm up the pool water. 3.Temp Probe error.
E6 Air in Cell	Pause electrolysis process	1. Filtration pump failure, no flow 2. Water valve closed 3.The air switch is not submerged in water.	Automatically resume normal operation, when the air switch is submerged in water.	1. Check filtration pump. 2. Check the water valve. 3. Check if the air switch is submerged in water.
E7 pH Sensor Failure	pH reading pauses at the latest value, Pause the acid adding process in Inverter Mode	Hardware communication error occurs inside the control unit.	Automatically resume normal operation, when hardware communication between the MCB and pH sampling module recovers.	1. Restart the control unit. 2. Disconnect the power for 10 seconds and re-plug the control unit. 3. Factory reset. 4. Please contact the After-Sales Center
E8 ORP Sensor Failure	ORP reading pauses at the latest value, Pause electrolysis process in Inverter Mode	Hardware communication error occurs inside the control unit.	Automatically resume normal operation, when hardware communication between the MCB and ORP sampling module recovers.	1. Restart the control unit. 2. Disconnect the power for 10 seconds and re-plug the control unit. 3. Factory reset. 4. Please contact the After-Sales Center.
E9 Power Module Failure	Pause electrolysis process	Hardware communication error occurs inside the control unit.	Automatically resume normal operation, when hardware communication between the MCB and power module recovers.	1. Restart the control unit. 2. Disconnect the power for 10 seconds and re-plug the control unit. 3. Factory reset 4. Please contact the After-Sales Center
Eb Salinity Module Failure	Pause electrolysis process	Hardware communication error occurs inside the control unit.	Automatically resume normal operation, when hardware communication between the MCB and Salinity Module recovers.	1. Restart the control unit 2. Disconnect the power for 10 seconds and re-plug the control unit. 3. Factory reset 4. Please contact the After-Sales Center

# 11 After-Sales Support

## Important Information for After-Sales Support

To ensure that we can assist you effectively when you contact our after-sales service, please have the following information ready:

### Product Information

- **Serial Number** (located on the nameplate)
- **Device Virtual ID** (available in the InverGo app)
- Device Model

### Problem Description

- Error Code Display
- Device Readings and Production Status
- Frequency and Timing of Issues

### Usage Environment

- Pool Size, Indoor/Outdoor
- Actual Salinity and ORP, pH, Free Cl Levels
- Water Flow and Filtration Time

Providing this information will help us resolve your issue more efficiently. Thank you!

